SELECTED ENGINEERING PROBLEMS

NUMBER 3

INSTITUTE OF ENGINEERING PROCESSES AUTOMATION
AND INTEGRATED MANUFACTURING SYSTEMS

Krzysztof DROBNY, Mariusz HETMAŃCZYK*

Institute of Engineering Processes Automation and Integrated Manufacturing Systems,
Faculty of Mechanical Engineering, Silesian University of Technology, Gliwice, Poland

*mariusz.hetmanczyk@polsl.pl

APPLICATION OF THE ILOGIC TECHNOLOGY, IMPLEMENTED IN THE INVENTOR SOFTWARE, TO THE REALIZATION OF A PARAMETERIZED MODEL OF A CYLINDRICAL GEAR – MODEL DESIGN AND ANALYSIS OF WORK CORRECTNESS

Abstract: The paper presents possibilities of usage of the iLogic rules to the development of parametric models and a subsequently verification of correctness and assessment at an angle of their performance in order to an adaptation of created model to the form of a standard solution of examined design, allowing generation of any structural variant, within the class of considered technical agents.

1. Introduction

A development of the new technical agent is a complex process which consists of a series of tasks, such as: an elaboration of the concept, a definition of materials and a subsequent verification of geometric and functional endurance. This process can be greatly assisted by using computer software on the basis of CAD/CAM programs [1, 2, 4].

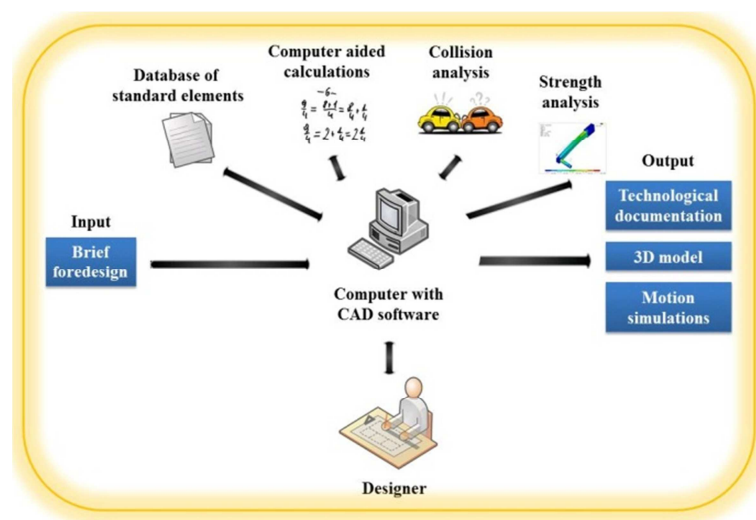

Fig. 1. Schematic diagram of a design process

The scope of a computer support, in the case of commercial design, is shown in Figure 1. Enumerated actions (Fig. 1) lead to a complete design documentation which is frequently used as a basis for a preparation and a development of manufacturing technologies of considered technical agents.

2. A development of a cylindrical gear 3D model

In case of the development of a gear model the authors assumed that the assembly will be carried out as a set of forged wheels. In order to weight reduction, especially in case of large-diameters, wheels have been defined in three design variants; which the selection criterion is based on the tip diameter of a gear (the parameter with identifier "d_{a2}") [3].

For this purpose, a model of the basic gear was prepared; the consequent step was an edition of a structural form by adding or subtracting solid bodies from the basic model and assigning them to particular variants characterized by their names. The next activity was connected with definition of a rule [5] making enable an automatic activation or a deactivation of individual basic blocks (with the command `Feature.IsActive()`=True/False). Selection of a chosen variant was carried out on the basis of the conditional statement If-Then, the code took the following form:

```

If Parameter("cylindrical_gear:1", "da2")<90 Then
  Feature.IsActive("cylindrical_gear:1", "t1_chamfer") = True
  Feature.IsActive("cylindrical_gear:1", "t2_holes_chamfer") = False
  Feature.IsActive("cylindrical_gear:1", "t2_t3_holes") = False
  Feature.IsActive("cylindrical_gear:1", "t2_wheel_hub_corner") = False
  Feature.IsActive("cylindrical_gear:1", "t2_wheel_hub_chamfer") = False
  Feature.IsActive("cylindrical_gear:1", "t2_wheel_hub") = False
  Feature.IsActive("cylindrical_gear:1", "t3_corner1") = False
  Feature.IsActive("cylindrical_gear:1", "t3_cut-out_chamfer") = False
  Feature.IsActive("cylindrical_gear:1", "t3_cut-out_wheel2") = False
  Feature.IsActive("cylindrical_gear:1", "t3_cut-out_wheel1") = False
End If
If Parameter("cylindrical_gear:1", "da2")>=90 Then
  Feature.IsActive("cylindrical_gear:1", "t1_chamfer") = False
  Feature.IsActive("cylindrical_gear:1", "t2_holes_chamfer") = True
  Feature.IsActive("cylindrical_gear:1", "t2_t3_holes") = True
  Feature.IsActive("cylindrical_gear:1", "t2_wheel_hub_corner") = True
  Feature.IsActive("cylindrical_gear:1", "t2_wheel_hub_chamfer") = True
  Feature.IsActive("cylindrical_gear:1", "t2_wheel_hub") = True
  Feature.IsActive("cylindrical_gear:1", "t3_corner1") = False
  ...
End If
If Parameter("cylindrical_gear:1", "da2")>=150 Then
  Feature.IsActive("cylindrical_gear:1", "t1_chamfer") = False
  Feature.IsActive("cylindrical_gear:1", "t2_holes_chamfer") = False
  Feature.IsActive("cylindrical_gear:1", "t2_t3_holes") = True

```

```

Feature.IsActive("cylindrical_gear:1", "t2_wheel_hub_corner") = False
Feature.IsActive("cylindrical_gear:1", "t2_wheel_hub_chamfer") = True
Feature.IsActive("cylindrical_gear:1", "t2_wheel_hub") = True



```

...

End If

The final result of the described rules is one of the three different design variants of toothed wheels shown in Table 1.

Table 1 Obtained construction variants of the cylindrical gear form

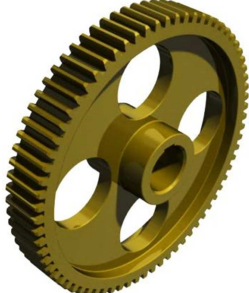
Diameter range		
$90 \leq d_{a2} \leq 150$ [mm]	$90 \leq d_{a2} < 150$ [mm]	$d_{a2} \geq 150$ [mm]
		

Another established assumption was a possibility of modifications of the torque value obtained on an input shaft and the output shaft with aid of a parallel key or a spline prism. This assumption is carried out in a similar manner to the choice of options changing the gear design variants, but in this case the selection method is realized by the user via a dedicated form in manual mode (instead automatic mode).

3. The assembly development

After the preparation of all of the required parts it is necessary to develop the assembly, in order to analysis of the co-operation and a proper fit of dimensions and shapes. Creation of an assembly requires execution of the following steps:

- an addition of modeled parts into the Inventor environment,
- a definition of the reciprocal bonds, in order to establishment of relations within the framework of considered assembly.

View of the elaborated model represents Figure 2. As a result of practical application of the required bonds (between the modeled elements) the finished helical gear unit model was obtained (Figure 3).

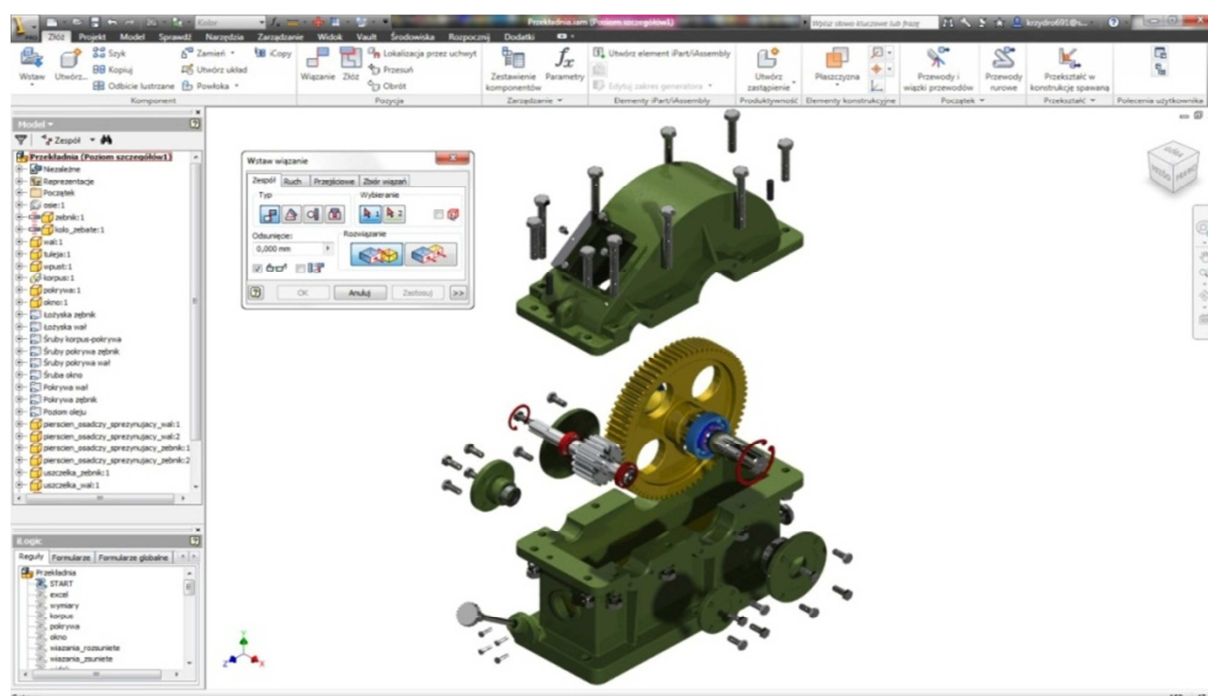

Fig.. 2. View of the cylindrical gear assembly

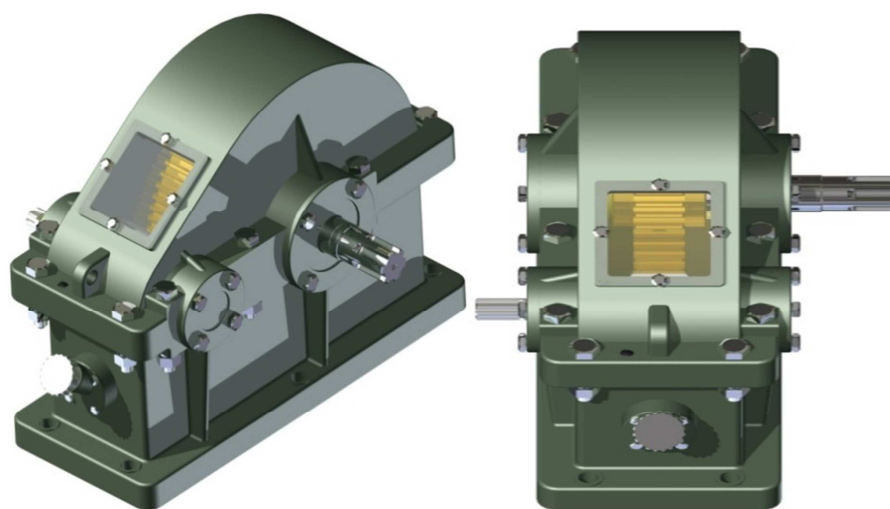

Fig. 3. View of composed cylindrical gear

After an elaboration of the assembly the authors proceed to the stage of analysis of the accuracy of the model generation and a determination of the correctness of reciprocal relations of all elements.

4. Verification and validation of the model rules

The model was verified at an angle of correctness of the settlement between the bearings and the housing flange - pinion shaft level. For this purpose, a section view tool was used (in the middle of the flange body), obtained sections are shown in Table 2.

Table 2 A verification of a settlement correctness of bearings

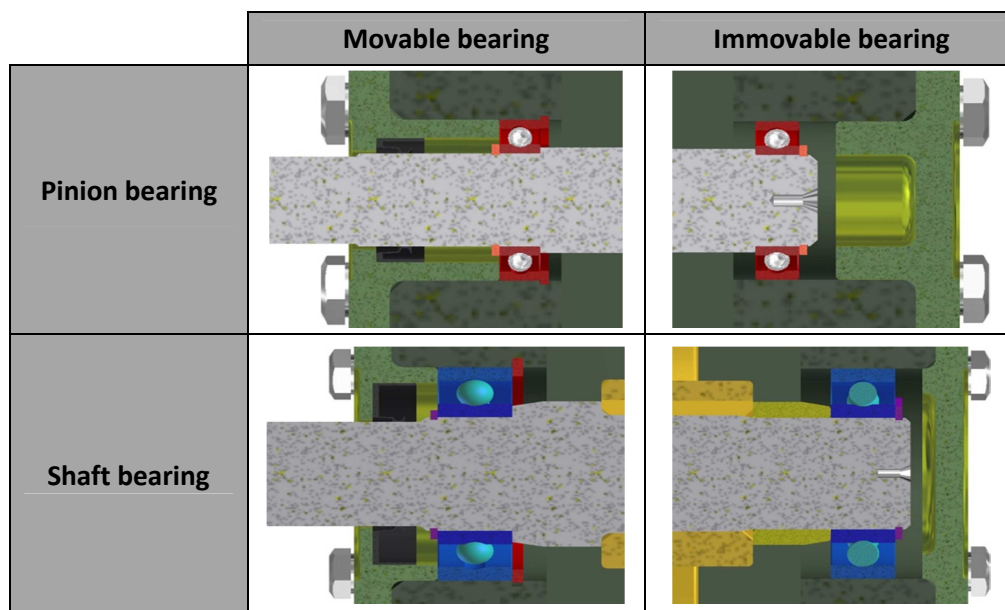

On the cross sections, contained in Table 2, all bearings are correctly fixed (there is no bearing collisions with other elements). Similarly was realized, the validation of a drilling holes used for joining screws of body, the flange and lateral covers (fixed to the body flanges and the lid). Successive step is measurement of values of relevant parameters such as: the distance from the zero axis, the length and diameter of the shaft steps, the distance from the pinion inner walls of the housing. The measured values were compared with the values contained in the spreadsheet.

The next step, in the verification of the created model, was carrying out a series of tests rely on validation studies of the model generation accuracy (depending on the parameters entered in the input gear form). For this purpose, into developed form were introduced a sample gear parameters, after this operation has been initiated a process of the model generation, and then comparison of the measured values of the parameters with the values contained in an Excel spreadsheet.

During testing it was noted that in the case of small values of the ratios and the input power the lateral covers were superimposed (Fig. 4 a).

To clear the described irregularity redesign of the lateral covers were executed, as a result of the lateral trimming of the cover flange (at the point of contact with the second cover Fig. 4b). This problem does not occur in case of the higher values of input parameters, so the cover is not modified (so that performance is less time-consuming).

It was assumed that the parameter determining the type of cover is the axes distance " a_w ". If the value is less than or equal to the sum of the two covers outside diameters, a trimming of the cover flange must be used, but if the value of " a_w " is greater than the sum of diameters, shear of cover is not required (Fig. 4 c).

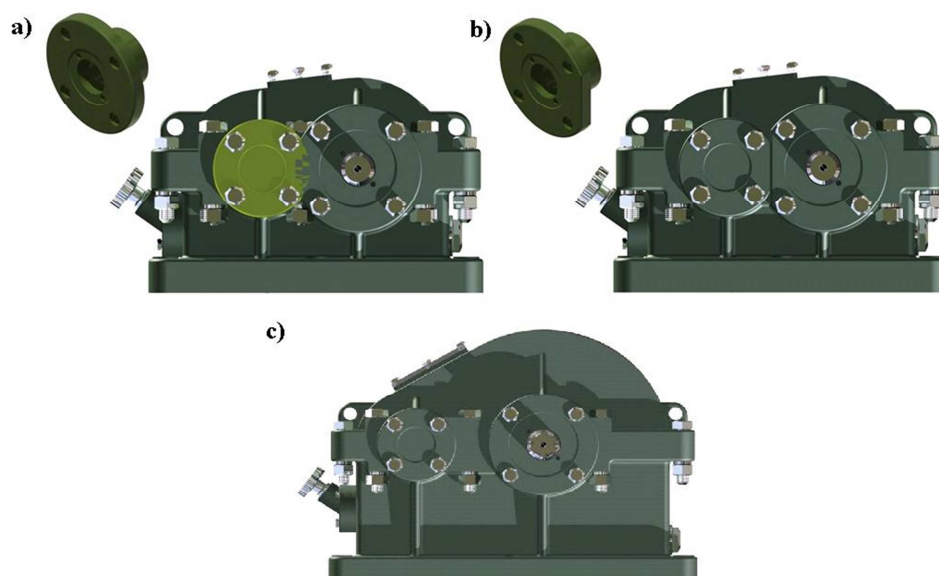

Fig. 4. The model view: a) with the superimposed lateral covers, b) a redesigned form, c) corresponding to the state where the value of " a_w " is greater than the sum of cover diameters

As a result of the verification, and modifications were obtained complete and properly generated model, based on freely selected input values inserted to the form of a helical gear transmission model.

5. Summary

This article shows the development method of a parametric model of the cylindrical gear and its subsequent verification based on the rules defined in the iLogic technology [6, 7].

An elaboration of parametric model is the process consuming a significant amount of time. Subsequent accomplishment of any changes is very simple, because all of interrelated dimensions automatically adjust to the new parameters, it is extremely important in complex structures, in which exist possibility of an ease omission of dimensions required manual changes of their numerical values.

References

1. Jaskulski A., Autodesk Inventor 10PL/10+: metodyka projektowania, Warszawa: Wydawnictwo Naukowe PWN, 2006, (In Polish).
2. Kapias K., Inventor praktyczne rozwiązania, Gliwice: Wyd. Helion, 2002, (In Polish).
3. Kurmaz L. W. i Kurmaz O. L., Projektowanie Wezłów i Części Maszyn, Kielce: Wydawnictwo Politechniki Świętokrzyskiej, 2006, (In Polish).
4. Nowakowski P., Wybrane techniki komputerowe w projektowaniu i wytwarzaniu, Gliwice: Wydawnictwo Politechniki Śląskiej, 2006, (In Polish).
5. Stasiak F., Zbiór ćwiczeń Autodesk Inventor 11, Łódź: ExpertBooks, 2006, (In Polish).
6. <http://autodesk-inventor-pl.typepad.com/my-blog/> (z dnia 16.03.2012).
7. <http://wikihelp.autodesk.com> (z dnia 10.02.2012)