

---

# SELECTED ENGINEERING PROBLEMS

NUMBER 3

INSTITUTE OF ENGINEERING PROCESSES AUTOMATION  
AND INTEGRATED MANUFACTURING SYSTEMS

---

Klaudiusz KLARECKI\*

Institute of Engineering Processes Automation and Integrated Manufacturing Systems,  
Faculty of Mechanical Engineering, Silesian University of Technology, Gliwice, Poland

\*klaudiusz.klarecki@polsl.pl

## TWO MODELLING METHODS OF HYDRAULIC DEVICES USING MATLAB/SIMULINK SOFTWARE

**Abstract:** In this paper two methods of modelling of hydraulic units were presented. Both in Matlab/Simulink software were realized. First on numerical solving of state equations was based, second - on the using of the elements from specialized library. These method were compared due to the laborious, the accuracy of their results and the possibility of adjusting of model parameters.

### 1. Introduction

As the simulation object the simple hydraulic unit was adopted. This hydraulic unit was consisted from:

- ideal pump with  $30 \text{ dm}^3/\text{min}$  flow rate max,
- pressure relief valve set 20 MPa (valve DBD 6 was assumed),
- orifice 1 mm diameter,
- volume of pressure line (including chambers of hydraulic elements)  $50 \text{ cm}^3$ ,
- hydraulic medium as HL-46 oil.

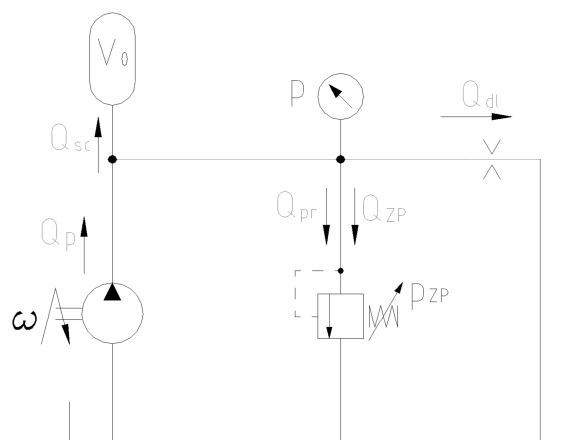

Fig. 1. Schema of modelled hydraulic unit

Was assumed that the discrete parameters model will be created. Modelled hydraulic unit on Fig. 1 is presented.

## 2. Numerical solution equations of hydraulic unit state

For modelling were created the flow equations and equations of motion describing each hydraulic unit. For modelled unit were necessary two flow equations and one equation of motion of relief valve poppet. The flow equations were as follows:

- equation of main flows:

$$Q_P = Q_{RV} + Q_{pm} + Q_{or} + Q_{co} \quad (1)$$

$Q_P$  - pump flow rate,

$Q_{RV}$  - flow rate of relief valve,

$Q_{or}$  - flow rate of orifice,

$Q_{co}$  - flow resulting from the oil compressibility

- equation of damping chamber flows (Fig. 2):

$$\frac{dp_0}{dt} = \frac{B}{V_{dc}} \left[ \frac{\pi dh^3}{12\mu l} (p - p_0) - \frac{dx}{dt} \left( \frac{\pi dh}{2} + \frac{\pi d^2}{4} \right) \right] \quad (2)$$

$B$  - oil modulus,

$V_{dc}$  - volume of the damping chamber,

$h$  - flow rate of orifice,

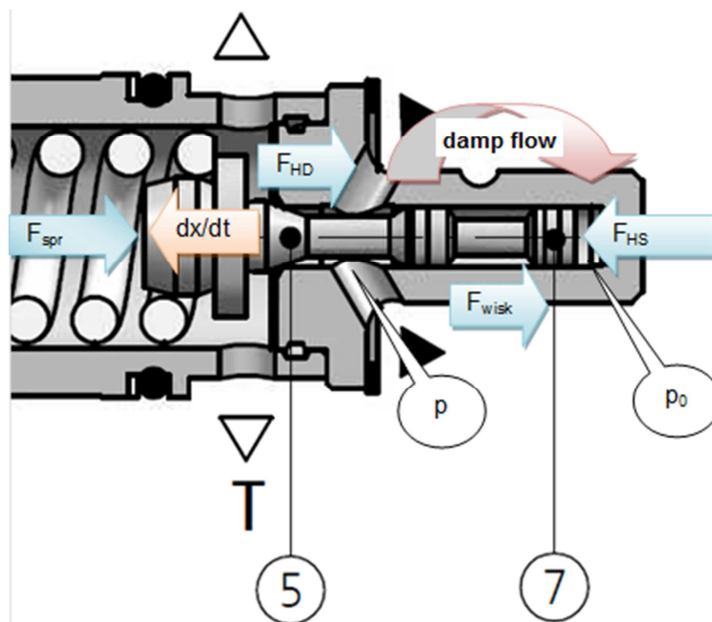

Fig.2. Flow due to the damping of valve poppet vibrations

The state equations were solved using the Matlab/Simulink software. For solver were accepted: Bogacki-Shampine method (ode23), variable step size ( $1 \cdot 10^{-9}$ s  $\div$   $1 \cdot 10^{-6}$ s). The results, as a pressure response to jump of pump flow rate, on Fig. 3 were showed.

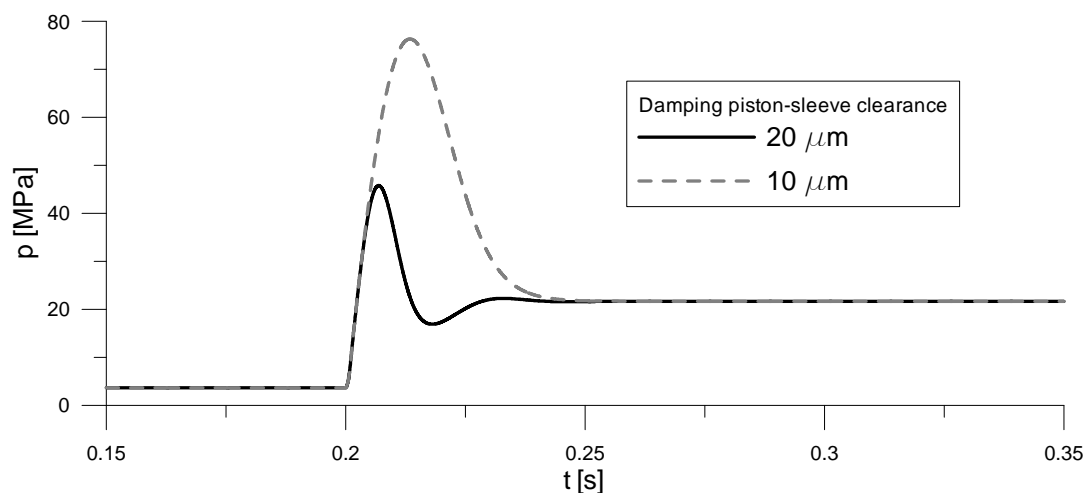

Fig.3. The course of pressure during the step change pump performance

### 3. Modelling of hydraulic unit using a Simscape/SimHydraulics library

The Matlab/Simulink is a most powerful CAE tool. This software included many libraries, for solution of different engineering problems. For modelling of hydraulic drives and steering is intended Simscape/Simhydraulics library. The model of hydraulic unit composed of items from the Simscape library on Fig. 4 is showed.

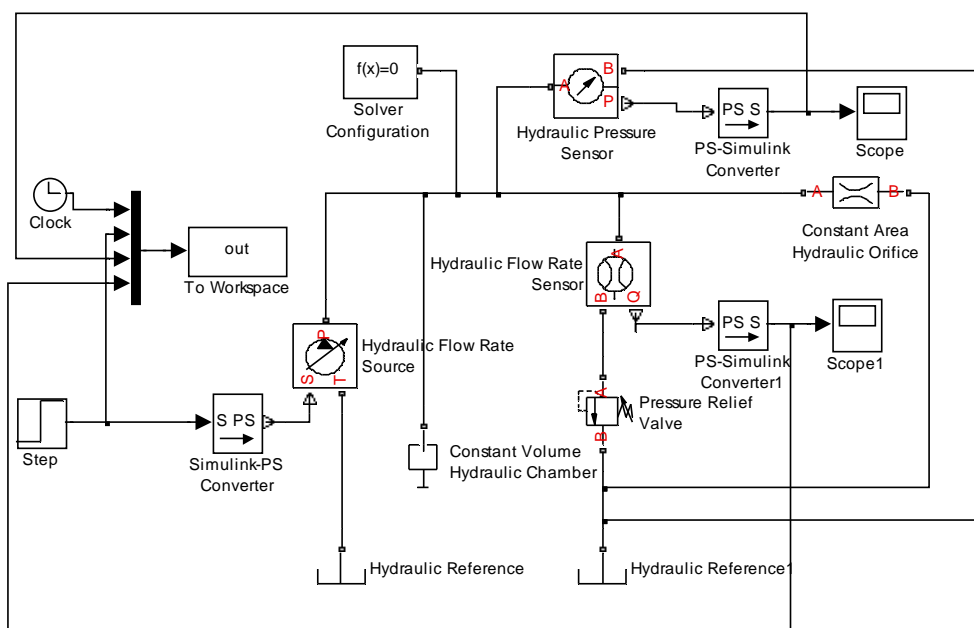

Fig.4. The model consisting of ready-made Simscape items

The simulation results, in comparison with previous, on Fig. 4 are showed. Pressures in steady states are similar, but the step responses are considerably different. This is due to the fact that the model of relief valve from the Simscape library does not include its dynamic properties.

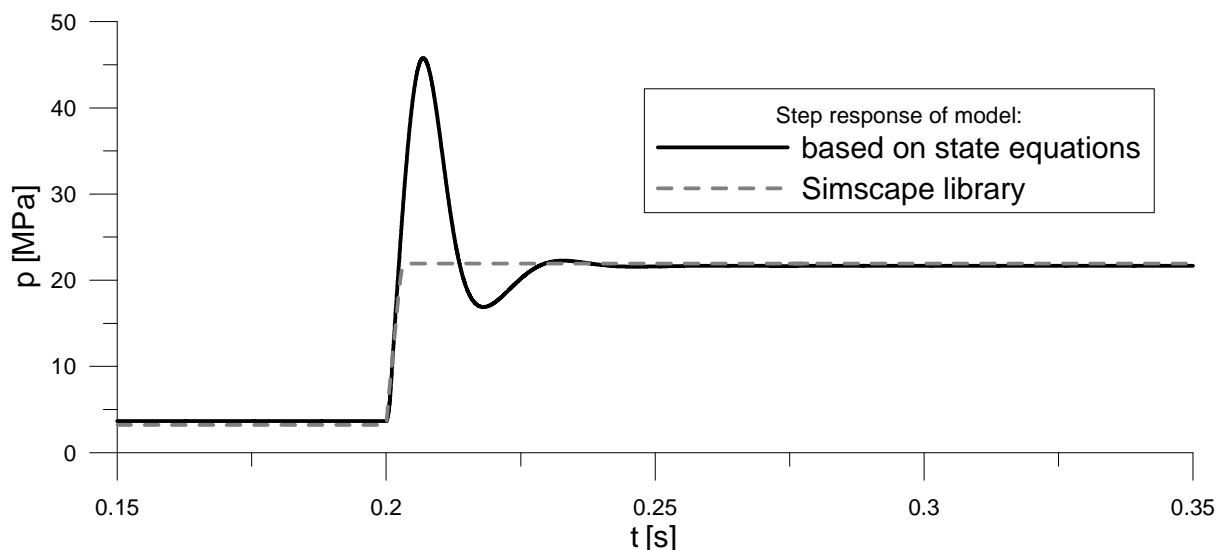

Fig.4. The model consisting of ready-made Simscape items

#### 4. Conclusion

The use of ready-made CAE tools accelerates hydraulic modelling. Their use also reduces the possibility of modelling errors. However, the proper use of CAE software is only possible to know his limitations. An example is analysed in this paper the issue.

Modelling of hydraulic systems (or systems containing hydraulic components) using tools from the library Simscape is very effective. But some of the elements of the library do not reflect all significant features of real objects. For example, is as the model of relief valve, missed its dynamic features. There is nothing more important in systems with high hydraulic capacitance, but not all hydraulic systems are as. In a one phrase: The art of modelling is to adopt the right tools

#### References

1. Tomasiak E.: Napędy i sterowanie hydrauliczne i pneumatyczne. Wydawnictwo Politechniki Śląskiej, Gliwice 2001, (In Polish).
2. Sheet of DBD relief valves: <http://www.ponar-silesia.pl/var/files/541/pl/2624.pdf> (25.09.2012).
3. Klarecki K.: Selected problems of hydraulic systems modeling. International Scientific-Technical Conference HYDRAULICS AND PNEUMATICS 2012, Wrocław 2012 (p. 360 – 369).